

MAESTR  AIR

GENESIS

A I R P U R I F I E R

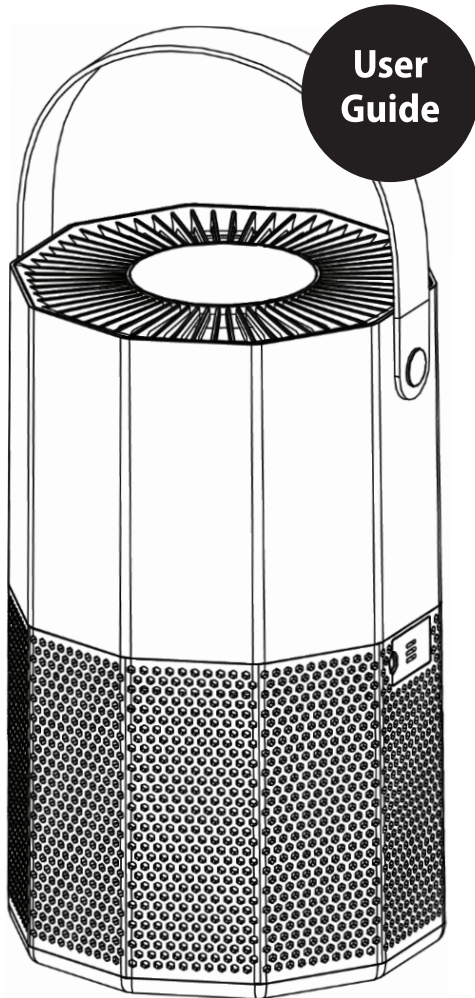

Please read these instructions carefully and keep them for future reference

www.maestroair.com.au

This product should be used only in accordance with the instructions outlined in this manual.

When using electrical appliances, basic precautions should always be followed to reduce the risk of fire, electric shock, and injury to persons, including the following:

- To avoid fire or shock hazard, plug the appliance directly into a 220 - 240 volt AC electrical outlet.
- To avoid fire hazard, NEVER put the cord under carpets or rugs or near heaters, radiators, open fires or stoves.
- DO NOT immerse in water or other liquids. DO NOT use near water.
- Children cannot recognize the hazards associated with the usage of electrical appliances. For this reason, always supervise children when they are near the air purifier.
- Always unplug the air purifier before moving it, opening the grill, changing filters, cleaning, or whenever the air purifier is not in use. When unplugging, pull by the plug and not the cord.
- NEVER drop or insert any object into any openings.
- DO NOT route cord under furniture or appliances. Arrange cord away from traffic areas and where it will not be tripped over.
- DO NOT operate any appliance with a damaged cord or plug, if motor fan fails to rotate, after the appliance malfunctions, or if it has been dropped or damaged in any manner.
- This appliance is intended for household use. Any other use is not recommended and may cause fire, electric shock, or injury.
- DO NOT use outdoors. DO NOT place anything on top of the unit.
- NEVER block the air openings, grills or outlets.
- DO NOT place on a soft surface as this could cause the unit to tip over, blocking the air intake or outtake opening.
- DO NOT attempt to repair or adjust any electrical or mechanical functions. Doing so will void your warranty. The electronics inside the Maestro Genesis Air Purifier contains no user serviceable parts.

WARNING: To reduce the risk of fire or electric shock, do not use this fan with any solid-state speed control device similar to a dimming switch.

Overview of the Maestro Genesis Air Purifier

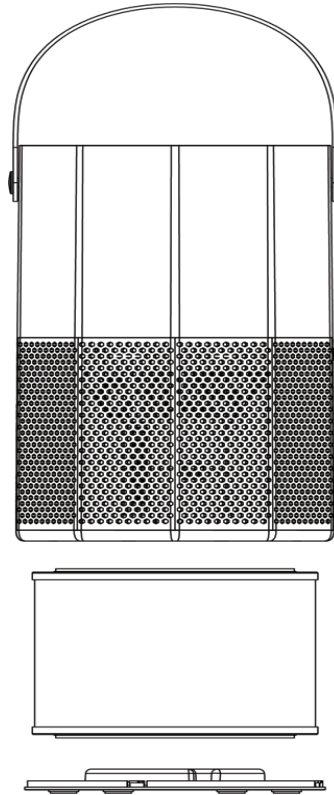

The Maestro Genesis Air Purifier utilises five levels of filtration technology to purify the air in your home:

STAGE 1 - PARTICULATE MEMBRANE

Traps larger particles: dirt, dust, particulates

STAGE 2 - ACTIVATED CARBON

Absorbs vapours, gases, smells, odours, pollens, allergens, VOCs

STAGE 3 - TRUE HEPA 13

Captures smoke, PPM 2 particles, virus, mould spores, pathogens >0.3m, dander, dust mites

STAGE 4 - UVC LIGHT TECHNOLOGY

Targets hepa 13 membrane surface

STAGE 5 - NEGATIVE ION GENERATOR

Produces negative ions that bind to positively charged particles in the air, then fall to the ground.

Operating Instructions

Carefully remove the air purifier from its box and plastic bag then position on a firm, level, and flat surface. For proper air flow, locate the unit at least 30 cm from any wall or furniture making sure none of the grills are obstructed.

Turn the unit upside down, twist off the base plate, and remove the Combination filter. Take the Combination filter from its plastic bag, replace the filter to the unit, and twist the base plate securely back into position. Discard the plastic bag. Plug the power cord into a 220 - 240V AC outlet. When moving the air purifier, always lift by the carrying handle.

The control panel on the Maestro Genesis Air Purifier looks like this:



POWER & FILTER RESET ICON

Press and release this icon to switch on or off.

AUTO ICON

Press this icon to switch Auto mode on or off. In Auto mode, the AUTO indicator is illuminated, and the system automatically adjusts according to the air quality in the room. The higher the pollution, the harder the purifier works to clear the air.

SPEED ICON

Press this icon to adjust fan speed to I, II, and III. Pressing this icon overrides the AUTO function.

SLEEP ICON

Press this icon to turn sleep mode on. The Sleep icon will flicker for 5 seconds, then all lights will be turned off and the appliance will run on low speed. Press any icon to quit Sleep mode and the machine will automatically revert to the setting before sleep mode was activated.

UV & IONISER ICON

Press this icon to switch the UVC lamp and Ioniser on and off.

CHILD LOCK ICON

Long press this button for 3 seconds to enter or exit the child lock mode.

TIMER ICON

By pressing this icon, the purifier can be timed to operate for 2h, 4h, or 8h stopping automatically when time elapses.

FILTER RESET ICON

The Filter Change Warning Light comes on and the Combination filter should be replaced. Long press Filter Reset icon for 3 seconds to reset.

AIR QUALITY INDICATOR

The LED strip in the centre of the control panel shows different colours to indicate the air quality:

BLUE INDICATOR

Good quality

(0~49 μ g/m³). Fan stays at standby level.

ORANGE INDICATOR

Moderate quality

(50~99 μ g/m³). Fan adjusts to Low.

YELLOW INDICATOR

Lightly polluted

(100~150 μ g/m³). Fan adjusts to Medium.

RED INDICATOR

Heavily polluted

(>150 μ g/m³). Fan adjusts to High.

When the Maestro Genesis Air Purifier is not in use, switch it off and unplug it.

Installing and Removing the Combination Filter

The Combination filter incorporates three filtration technologies:

Particulate Filter: Captures dust, particulates and allergen particles.

Activated Carbon Filter: Absorbs gases and odors.

HEPA 13 Filter: Captures fine particulates, smoke, pollen, and other allergens.

When the **Filter Reset** indicator is illuminated on the display, the Combination filter needs to be replaced.

1. Carefully turn the unit upside down and remove the base plate by screwing it off the unit. Remove the old filter.
2. Remove the replacement Combination filter from its packaging and insert it into the unit.
3. Reattach the base plate by screwing it back into position.
4. Long press **Filter Reset** icon for 3 seconds to reset it.

Maintaining the Air Purifier and Combination Filter

The Maestro Genesis Air Purifier should be cleaned once every month. Use a clean, dry, soft cloth to wipe the external surface of the Maestro Genesis Air Purifier. Do NOT stick any foreign objects or your fingers inside the unit. Do NOT use petrol, benzene, thinner, alcohol, solvents, harsh cleaners, etc. on or in the unit while cleaning as they will damage the product.

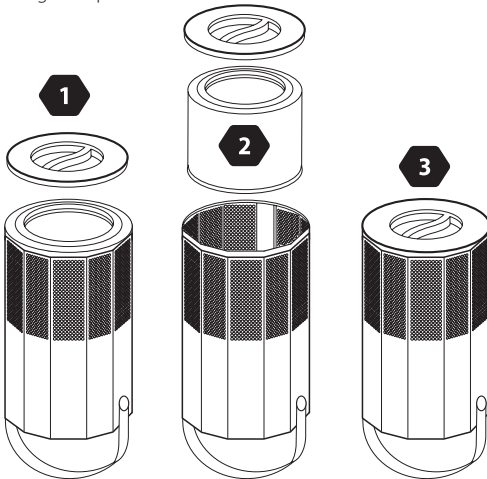

2-Year Warranty

So Simple Solutions Pty Limited certifies that the Maestro Genesis Air Purifier is free from defects in material and workmanship from the date of purchase. This warranty does not cover damage caused by misuse or abuse, accident, not maintaining the product as instructed, alteration to the product, or any other conditions beyond the control of So Simple Solutions. So Simple Solutions shall not be responsible for any type of incidental, consequential, or special damages. This warranty provides you with specific legal rights. You may have additional rights which may vary from state to state. Because of individual state regulations, some of the above limitations and exclusions may not apply to you. Please do not hesitate to contact So Simple Solutions at:

4 Pirelli Street Southport 4215 • 1800 616 248 • info@maestroair.com.au • Country of Origin: PRC

Ongoing Filter Maintenance

The Combination filter should also be cleaned once every month. There is only one section to clean, the pre-filter which is wrapped around the Combination filter. To clean the prefilter:

1. Carefully turn the unit upside down and remove the base plate by screwing it off the unit. Remove the filter.
2. Wrapped around the outside of the Combination filter is the white particulate filter or pre-filter. This filter cannot be removed.
3. Clean the dirt, dust and pollens off the particulate filter outside with a vacuum, soft cloth or brush with gentle bristles.
4. Ensure the particulate filter is completely clean before re-inserting it into the unit and screwing the base plate back into position.

Periodic Maintenance Warranty Consideration

Regular cleaning of pre filter is required. Failure to do so may restrict proper air flow through the system that may overheat motor or fan resulting in catastrophic damage. Failure to properly maintain and clean the pre filter may result in warranty being voided.